

**SOUTHERN AFRICA GLOBAL
COMPETITIVENESS HUB**



Corridor Performance Measurement

Nelspruit

Evans Marowa

18 October 2007



Need for Performance Measurement

- **Confirm progress against set strategic initiatives**
- **Note variations and take remedial measures**

Performance Indicators

- **Corridor Utilization**
 - **Cargo Traffic Volumes**
 - **Vehicle Traffic**
- **Facilitation Indicators**
 - **Transit Time**
 - **Transit Processes Time**
- **Transaction Costs**

Corridor Network

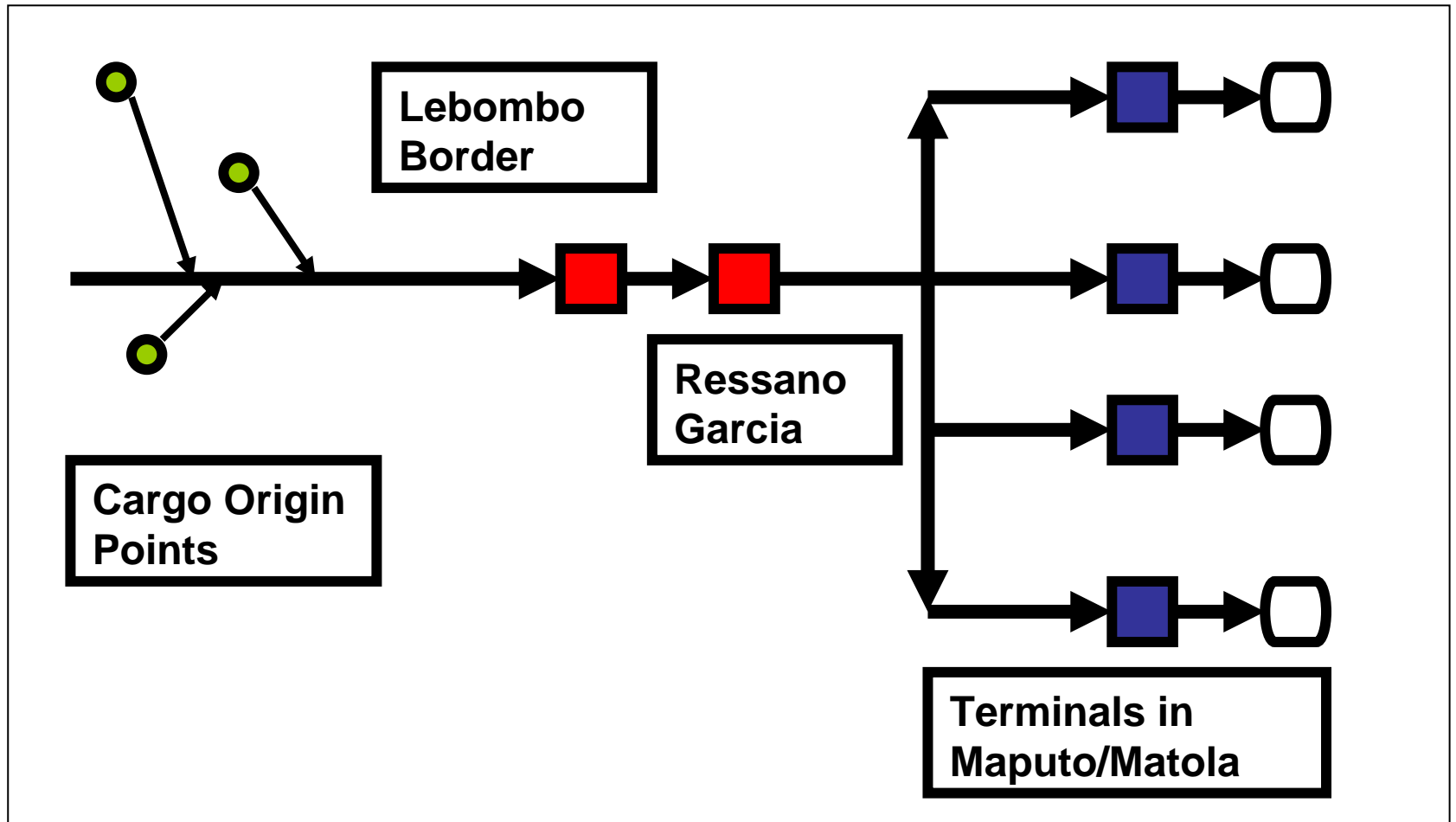

Data Collection & Processing

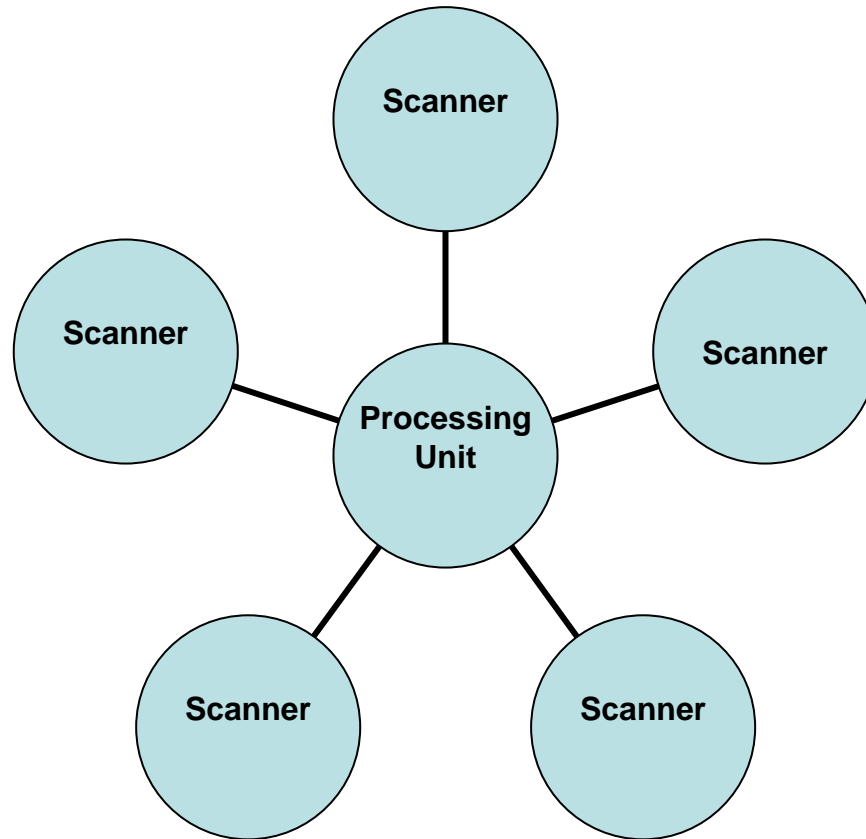

Implications of System

- **Public Private Partnership**
 - **Cargo Owners**
 - **Logistics Services Providers**
 - **Border Post Control Agencies**
 - **Terminal Operators**
 - **Terminal Control Agencies**

**SOUTHERN AFRICA GLOBAL
COMPETITIVENESS HUB**



Evans MAROWA

Transport Advisor

Trade Facilitation & Capacity Building

Tel.: +267 3900 884

Mobile: +267 7172 7161

Email: emarowa@satradehub.org

info@satradehub.org

www.satrdaehub.org